

# PMD VARIO

Telaio porta attrezzi a colonna mobile - Tool holder frame with mobile column  
Cadre porte-outils à colonne mobile - Multigeräteträger mobil

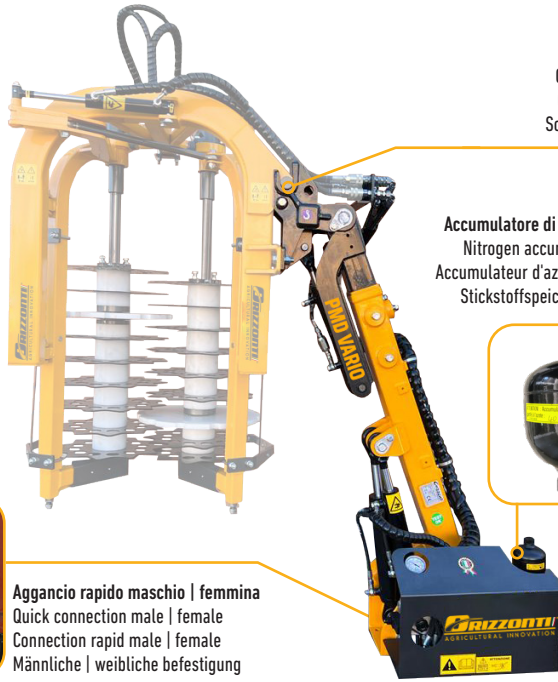

Aggancio rapido  
Quick connection  
Connection rapid  
Schnelle kopplung

Accumulatore di azoto per dischi  
Nitrogen accumulator for discs  
Accumulateur d'azote pour disques  
Stickstoffspeicher für Scheiben



Aggancio rapido maschio | femmina  
Quick connection male | female  
Connection rapid male | female  
Männliche | weibliche befestigung

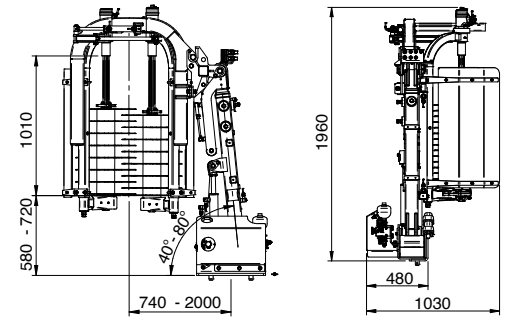
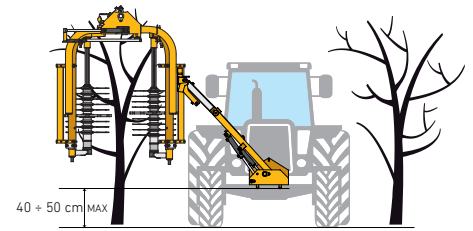

<b>COD.</b>	<b>Movimenti - Movements - Mouvements - Bewegungen</b>	<b>Joystick</b>	<b>Distributore</b>	<b>Oil - Pressure</b>
<b>104605J</b>	6+1  + <b>ON/OFF MOTOR</b>		310	50 l/min 180 bar max
<b>+3 MOVIMENTI LIBERI   +3 FREE MOVEMENTS   +3 MOUVEMENTS LIBRE   +3 FREI BEWEGUNGEN</b>				



Apertura idraulica tunnel  
Hydraulic tunnel opening  
Ouverture du tunnel hydraulique  
Öffnung des Hydrauliktunnels

Ø 50 cm di lavoro  
Working Ø 50 cm  
Ø 50 cm de travail  
Ø 50 cm der Arbeit  
Ø 50 cm  
L. 25 cm  
Ø 4 mm

Ecology L. 40 cm

Spollonatrice/taglio erba a fili  
Shoot removing head/grass cutting machine with wires  
Empampreuse/tondeuses à gazon avec fils  
Rebstamputzer/Gras Schneidemaschine mit Drähten mit Litzen

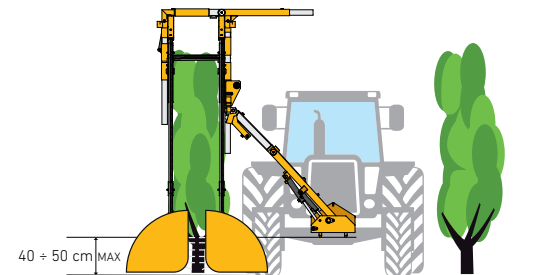

<b>COD.</b>	<b>Movimenti - Movements - Mouvements - Bewegungen</b>	<b>Joystick</b>	<b>Distributore</b>	<b>Oil - Pressure</b>
<b>1U46500</b>	+ <b>ON/OFF MOTOR</b>		160	30 l/min 180 bar max

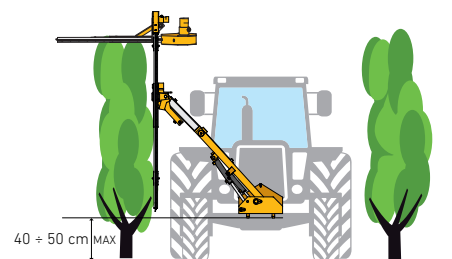
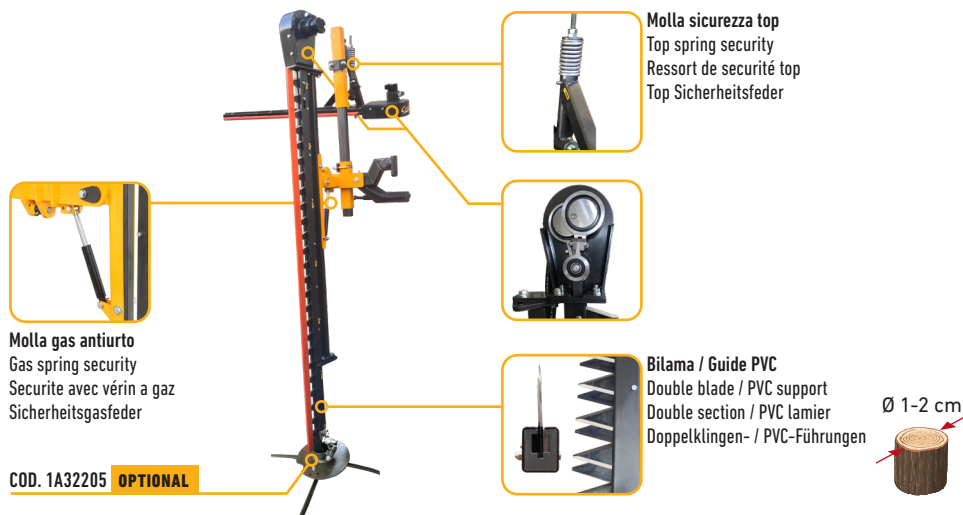

<b>COD.</b>	<b>Movimenti - Movements - Mouvements - Bewegungen</b>	<b>Joystick</b>	<b>Distributore</b>	<b>Oil - Pressure</b>
<b>1U46320</b>	+ <b>ON/OFF MOTOR</b>			280 30 l/min 180 bar max

**STAFFE PER TRATTORI E SERBATOI - TRACTOR BRACKETS AND OIL TANKS - SUPPORTS ET RÉSERVOIRS DE TRACTEUR - TRAKTORHALTERUNGEN UND TANKS** **Pag. 59**

<b>OPTIONAL</b>	<b>Descrizione - Description - Description - Beschreibung</b>	
<b>1A32205</b>	<b>Convogliatore alzatralci idraulico - Hydraulic conveyor</b> Convoyeur hydraulique - Hydraulischer Hebebandförderer	

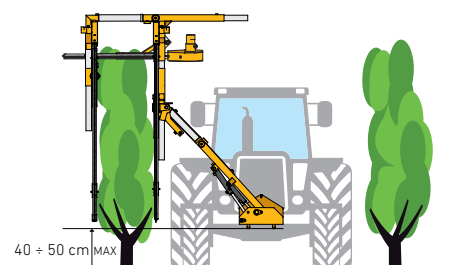
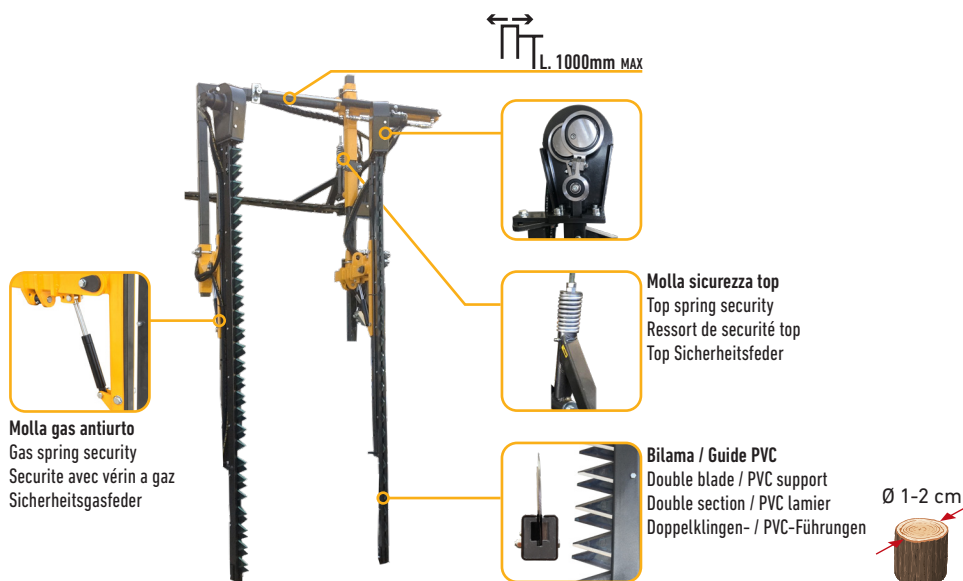

<b>COD.</b>	<b>Movimenti - Movements - Mouvements - Bewegungen</b>	<b>Joystick</b>	<b>Distributore</b>	<b>Oil - Pressure</b>
<b>1U46325</b>	+ <b>ON/OFF MOTOR</b>			190 30 l/min 180 bar max

**STAFFE PER TRATTORI E SERBATOI - TRACTOR BRACKETS AND OIL TANKS - SUPPORTS ET RÉSERVOIRS DE TRACTEUR - TRAKTORHALTERUNGEN UND TANKS** **Pag. 59**

<b>OPTIONAL</b>	<b>Descrizione - Description - Description - Beschreibung</b>	
<b>1A32200</b>	<b>2 Convogliatori alzatralci idraulici - 2 Hydraulic conveyors</b> 2 Convoyeur hydrauliques - 2 Hydraulische Hebebänder	

**Molla gas antiurto**  
Gas spring security  
Securite avec vérin a gaz  
Sicherheitsgasfeder

**Molla sicurezza top**  
Top spring security  
Ressort de sécurité top  
Top Sicherheitsfeder

**Cinghie autotensionanti**  
Self tensioning belts  
Courroies auto tendues  
Selbstspannende Riemen

**Coltelli Ø 41 cm. - 2500 rpm**  
Knives Ø 41 cm. - 2500 rpm  
Couteaux Ø 41 cm. - 2500 rpm  
Messer Ø 41 cm. - 2500 rpm

Ø 1-2 cm

40 ÷ 50 cm MAX

COD.	Movimenti - Movements - Mouvements - Bewegungen	Joystick	Distributore	Oil - Pressure
<b>1U46330</b>	A = 4 B = 2 			160 30 lt/min 180 bar max
<b>1U46331</b>	A = 5 B = 2 			280 30 lt/min 180 bar max

OPTIONAL	Descrizione - Description - Description - Beschreibung
<b>1A324000</b>	<b>Cottello inclinabile a regolazione meccanica - Tilting knife with mechanical adjustment</b> Couteau incliné avec réglage mécanique - Kippmesser mit mechanischer Einstellung

**Molla gas antiurto**  
Gas spring security  
Securite avec vérin a gaz  
Sicherheitsgasfeder

**Molla sicurezza top**  
Top spring security  
Ressort de sécurité top  
Top Sicherheitsfeder

**Cinghie autotensionanti**  
Self tensioning belts  
Courroies auto tendues  
Selbstspannende Riemen

**Coltelli Ø 41 cm. - 2500 rpm**  
Knives Ø 41 cm. - 2500 rpm  
Couteaux Ø 41 cm. - 2500 rpm  
Messer Ø 41 cm. - 2500 rpm

Ø 1-2 cm

40 ÷ 50 cm MAX

COD.	Movimenti - Movements - Mouvements - Bewegungen	Joystick	Distributore	Oil - Pressure
<b>1U46335</b>	A = 3 B = 2 			180 30 lt/min 180 bar max
<b>1U46336</b>	A = 4 B = 2 			215 30 lt/min 180 bar max
<b>1U46337</b>	A = 5 B = 2 			227 30 lt/min 180 bar max

OPTIONAL	Descrizione - Description - Description - Beschreibung
<b>1A324002</b>	<b>Doppio cottello inclinabile DX/SX a regolazione meccanica - Double conveyor knife R/L with mechanical adjustment</b> Double couteau inclinabile D/G avec réglage mécanique - Doppelkippmesser R/L mit mechanischer Einstellngt
<b>1A32202</b>	<b>2 Convogliatore alzatracci su barra verticale con REGOLATORE DI FLUSSO - 2 Thread lifting conveyor on vertical bar with FLOW REGULATOR</b> 2 Convoyeur hydraulique sur barre verticale avec RÉGULATEUR DE DÉBIT - 2 Fadenhebeförderer auf vertikaler Stange mit STRÖMUNGSREGLER
<b>1A32204</b>	<b>2 Convogliatore alzatracci su cottello inclinato con REGOLATORE DI FLUSSO - 2 Thread lift conveyor on inclined knife with FLOW REGULATOR</b> 2 Convoyeur hydraulique sur couteau incliné avec RÉGULATEUR DE DÉBIT - 2 Fadenhebeförderer auf Schrägmesser mit DURCHFLOSSREGLER



8+8 Dischi DI SERIE  
8+8 Discs AS STANDARD  
8+8 Disques DE SÉRIE  
8+8 Scheiben SERIENMÄSSIG

**DI SERIE**

**OPTIONAL**

COD. 1A45031

N° 12 = L. 100 cm  
N° 10 = L. 80 cm  
N° 08 = L. 60 cm

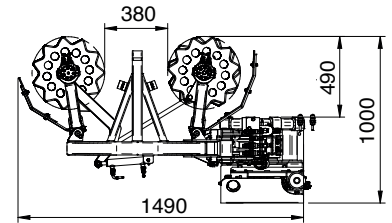
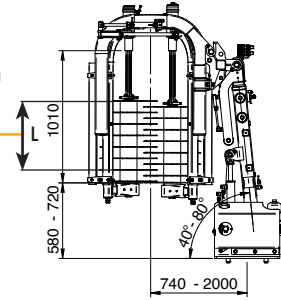

COD.	Movimenti - Movements - Mouvements - Bewegungen	N°	Joystick	Distributore	Oil - Pressure
1U46450	+ ON/OFF MOTOR	8+8			190 30 l/min 180 bar max

OPTIONAL	Descrizione - Description - Description - Beschreibung	
1A45030	Maggiorazione/Deiezione per coppia dischi taglienti in HARDOX - Increase/deduction for pair of HARDOX discs Supplément/Dédution pour paire de disques à tronçonner en HARDOX - Zuschlag/abzug für ein Paar Schneidscheiben in HARDOX	
1A45031	Coppia dischi salva-palo in PVC folli - Pair of pole-friendly PVC idle discs Disques de sécurité en PVC - Paar polfreundliche PVC-Leertauscheiben	NON PER - Not for - Pas pour - Nicht für 12+12 Dischi - Discs - Disques - Scheiben
1A45032	Coppia anteriore barre bilame L. 100 cm - Front pair of double-blade bars L. 100 cm Paire de barres double lame L. 100 cm avant - Vorderes Paar Doppelklingen L. 100 cm	



4+4 Dischi DI SERIE  
4+4 Discs AS STANDARD  
4+4 Disques DE SÉRIE  
4+4 Scheiben SERIENMÄSSIG

**DI SERIE**

**OPTIONAL**

COD. 1A45031

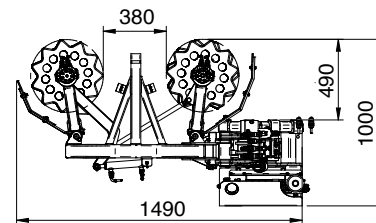

	<b>MOD. GUYOT</b>					
COD.	Movimenti - Movements - Mouvements - Bewegungen	N°	Joystick	Distributore	Oil - Pressure	
1U46451	+ ON/OFF MOTOR	4+4			120 30 l/min 180 bar max	

OPTIONAL	Descrizione - Description - Description - Beschreibung	
1A45030	Maggiorazione per coppia dischi taglienti in HARDOX - Increase for pair of HARDOX discs Supplément pour paire de disques à tronçonner en HARDOX - Zuschlag für ein Paar Schneidscheiben in HARDOX	
1A45031	Coppia dischi salva-palo in PVC folli - Pair of pole-friendly PVC idle discs Disques de sécurité en PVC - Paar polfreundliche PVC-Leertauscheiben	NON PER - Not for - Pas pour - Nicht für 5+5 Dischi - Discs - Disques - Scheiben
1A45032	Coppia anteriore barre bilame L. 100 cm - Front pair of double-blade bars L. 100 cm Paire de barres double lame L. 100 cm avant - Vorderes Paar Doppelklingen L. 100 cm	